

2.54mm PITCH 2 PIECE CONNECTOR DIN CONNECTORS

8300/8400 SERIES

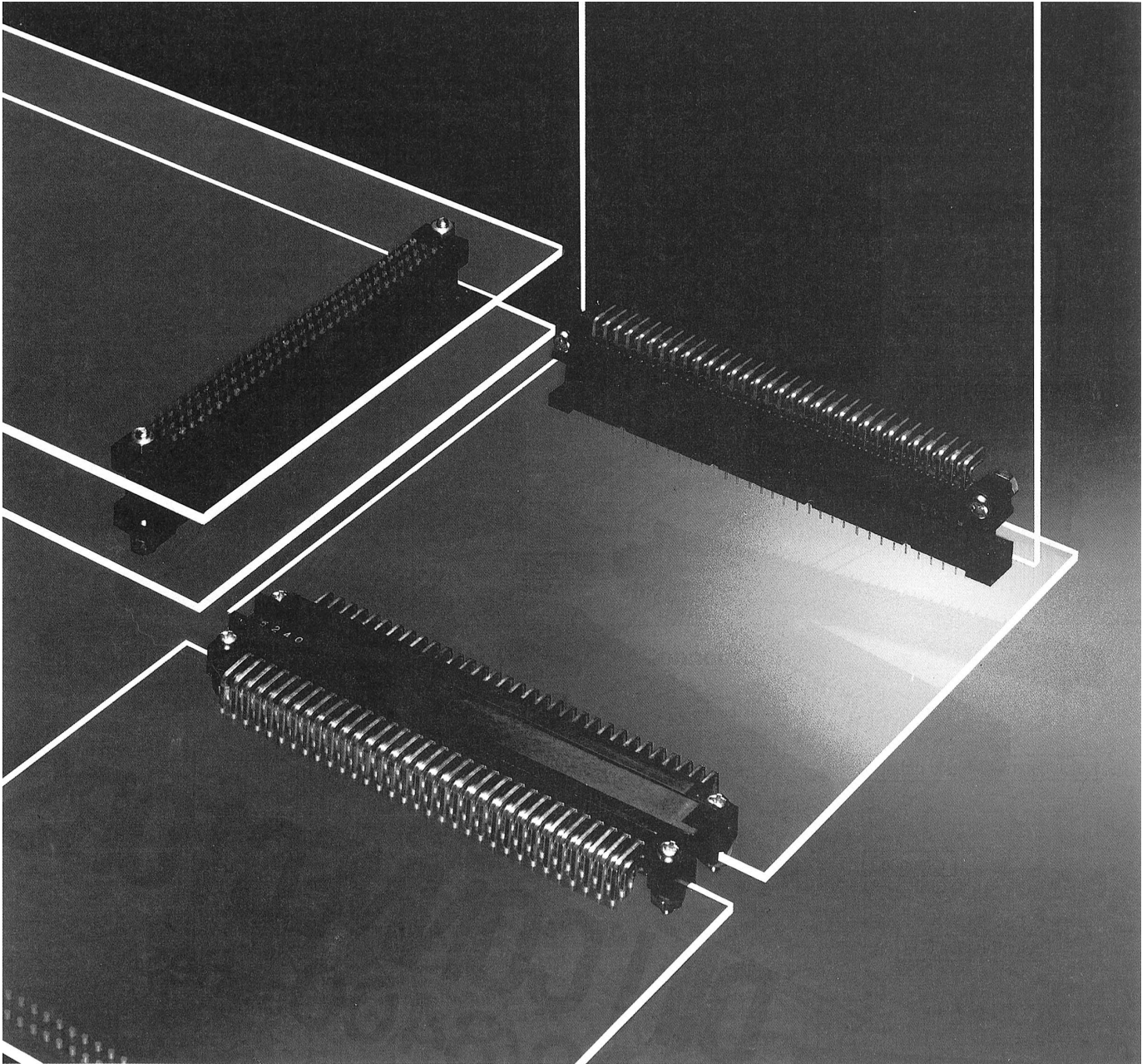



KEL has successfully developed a new economical DIN manufacturing technology.

DIN CONNECTORS

KEL has successfully produced a new economical DIN connector by utilizing the original design technology and accumulated production experience. DIN offers lower cost and higher contact performance than card edge connectors. DIN's mating reliability is independent of board thickness, surface treatment, and dimensional accuracy easing board requirements. This advantage combined with low connector cost offers substantial advantages. KEL, whose 8300 series complies with DIN41612/IEC603-2 standards, has responded to the need for diversified mating combinations (horizontal, vertical, and stacked mating) with the addition of its inverse type 8400 series. KEL's new "VA" type is completely changing the image of DIN connectors by offering superior performance with polarity variations at an economical price.

FEATURES

- A total price advantage over card-edge type connectors.
- Allows standardization to DIN41612 and IEC603-2
- Several varieties satisfying most applications.
- Horizontal, Vertical, and Stacked mating combinations.
- Mating is easy and reliable due to
- unique contact design.
- RoHS compliance

■ 8330-8340 SERIES, VA product (Standard type, Complies with DIN/IEC)

- 2 rows : 32, 44, 50, 64, 90, 100 contacts
- 3 rows : 48, 96 contacts

■ 8430-8440 SERIES, VA product (Inverse type, Complies with DIN)

- 2 rows : 32, 44, 50, 64, 90, 100 contacts
- 3 rows : 48, 96 contacts

■ 8300-8310 SERIES (Standard type, Complies with DIN/IEC)

- 2 rows : 32, 50, 64 contacts
- 3 rows : 48, 96 contacts

■ 8400-8410 SERIES (Inverse type, Complies with DIN)

- 2 rows : 64 contacts
- 3 rows : 96 contacts

SPECIFICATIONS

MATERIAL

- Insulator :
(Glass-filled P.B.T. (UL94V-0))
(Glass-filled P.E.T. (UL94V-0))
8400-8410 series
- Contact : Copper alloy
- Contact finish :
Contact area - Gold plating over nickel
Terminal - Tin copper over nickel

ELECTRIC ABILITY

- Current rating :
2A/1 pin (VA type = 1A/1 pin)
- Contact resistance :
20 mΩ Max.
- Dielectric withstanding voltage :
1,000V AC/1 minute
- Insulation resistance :
10⁶ MΩ Min. 500V DC
10⁵ MΩ Min. 500V DC (after test)

MECHANICAL ABILITY

- Insertion force :
120g MAX./1 pin
- Withdrawal force :
15g MIN./1 pin
- Withdrawal force per 1 pin with
0.56mm steel gage :
0.15N (15.3g) MIN.
- Contact retention :
20N (2.04kg) MIN.
- Operating temperature :
-55°C to +85°C

connector by utilizing our originality in

8331-□□□-294□-□□□-N

R/A Pin Header, 2 row type

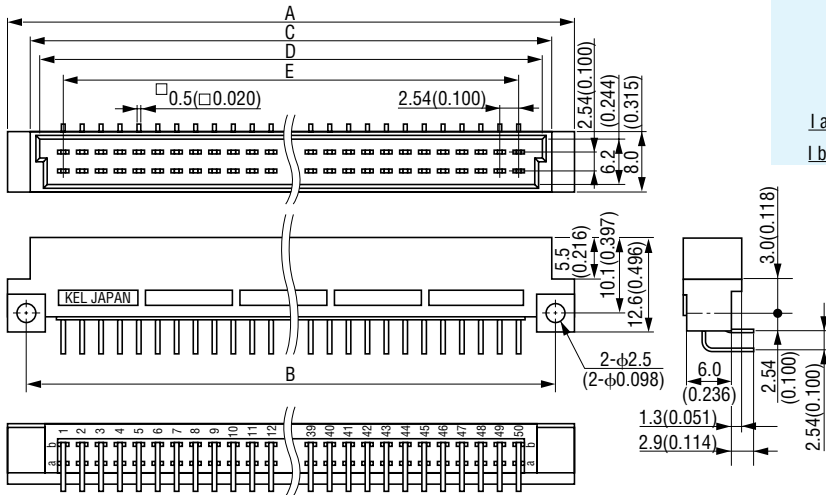
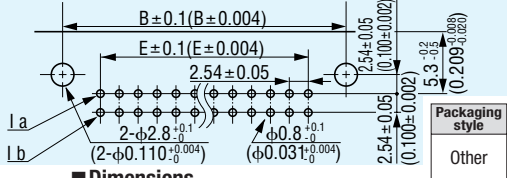
PCB Layout (Component Side View)

■ Dimensions

No. of contacts	A	B	C	D	E	Number of packaging
32	53.26 (2.097)	48.26 (1.900)	46.86 (1.845)	44.66 (1.758)	38.10 (1.500)	300
44	68.50 (2.697)	63.50 (2.500)	62.10 (2.445)	59.90 (2.358)	53.34 (2.100)	260
50	76.12 (2.839)	71.12 (2.800)	69.72 (2.745)	67.52 (2.658)	60.96 (2.400)	240
64	93.90 (3.697)	88.90 (3.500)	87.50 (3.445)	85.30 (3.358)	78.74 (3.100)	180
90	126.92 (4.997)	121.92 (4.800)	120.52 (4.745)	118.32 (4.658)	111.76 (4.400)	130
100	139.62 (5.497)	134.62 (5.300)	133.22 (5.245)	131.02 (5.158)	124.46 (4.900)	120

8341-□□□-294□-□□□-N

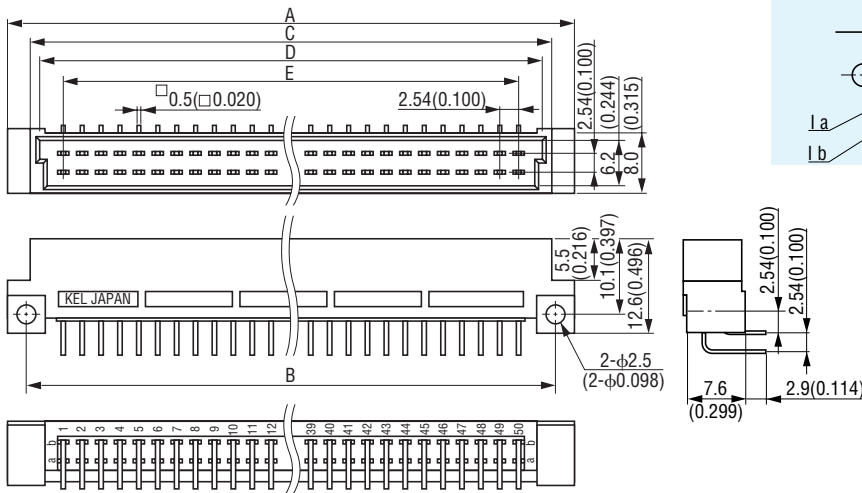
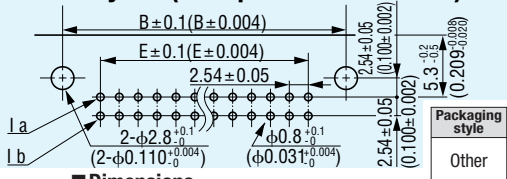
R/A Pin Header (Flush Mounting), 2 row type

PCB Layout (Component Side View)

■ Dimensions

No. of contacts	A	B	C	D	E	Number of packaging
32	53.26 (2.097)	48.26 (1.900)	46.86 (1.845)	44.66 (1.758)	38.10 (1.500)	300
44	68.50 (2.697)	63.50 (2.500)	62.10 (2.445)	59.90 (2.358)	53.34 (2.100)	260
50	76.12 (2.839)	71.12 (2.800)	69.72 (2.745)	67.52 (2.658)	60.96 (2.400)	240
64	93.90 (3.697)	88.90 (3.500)	87.50 (3.445)	85.30 (3.358)	78.74 (3.100)	180
90	126.92 (4.997)	121.92 (4.800)	120.52 (4.745)	118.32 (4.658)	111.76 (4.400)	130
100	139.62 (5.497)	134.62 (5.300)	133.22 (5.245)	131.02 (5.158)	124.46 (4.900)	120

8330-□□□-283□-□□□-N

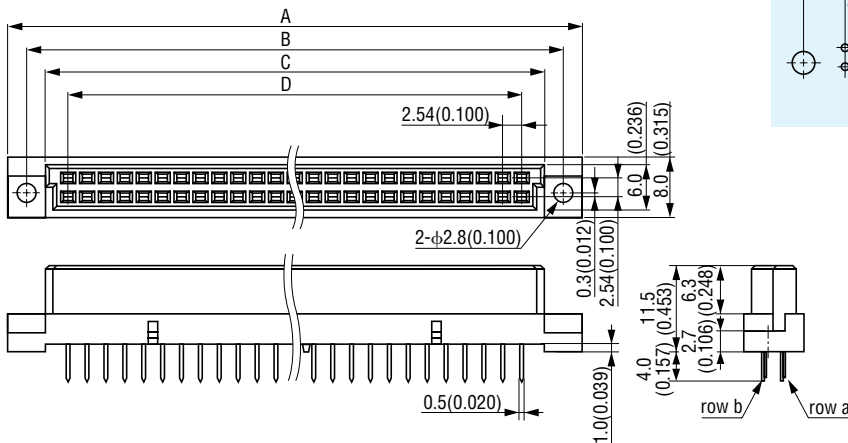
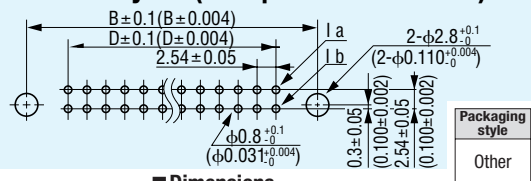
Socket Receptacle, 2 row type

PCB Layout (Component Side View)

■ Dimensions

No. of contacts	A	B	C	D	Number of packaging
32	54.36 (2.140)	49.36 (1.943)	44.26 (1.743)	38.10 (1.500)	300
44	69.60 (2.740)	64.60 (2.543)	59.50 (2.343)	53.34 (2.100)	260
50	77.22 (3.040)	72.22 (2.843)	67.12 (2.643)	60.96 (2.400)	240
64	95.00 (3.740)	90.00 (3.543)	84.90 (3.343)	78.74 (3.100)	180
90	128.02 (5.040)	123.02 (4.843)	117.92 (4.643)	111.76 (4.400)	120
100	140.72 (5.540)	135.72 (5.343)	130.62 (5.143)	124.46 (4.900)	60

8331-□□□-294□-□□□-N

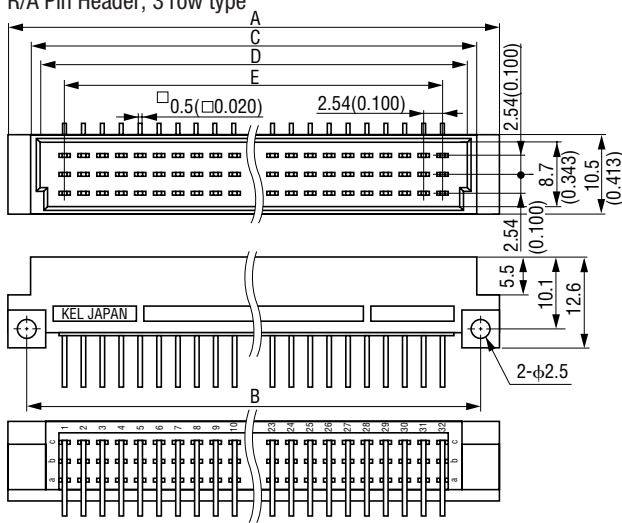
R/A Pin Header, 3 row type



PCB Layout (Component Side View)

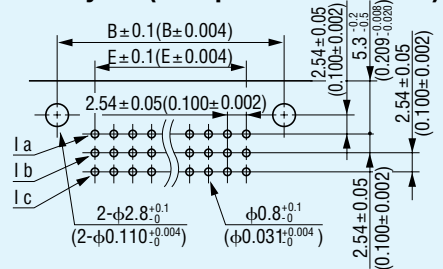

■ Dimensions

No. of contacts	A	B	C	D	E	Number of packaging
48	53.26 (2.097)	48.26 (1.900)	46.86 (1.845)	44.66 (1.758)	38.10 (1.500)	180
96	93.90 (3.697)	88.90 (3.500)	87.50 (3.445)	85.30 (3.358)	78.74 (3.100)	100

Packaging style
Other

8341-□□□-294□-□□□-N

R/A Pin Header (Flush Mounting), 3 row type

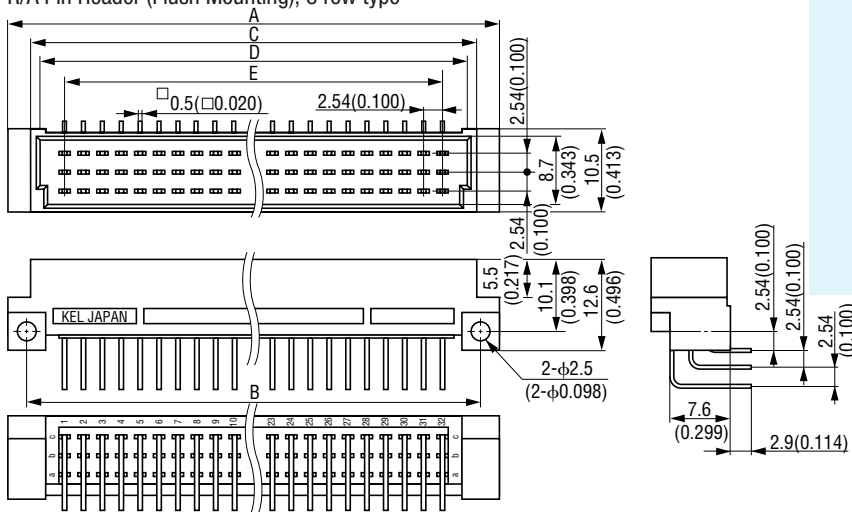

PCB Layout (Component Side View)

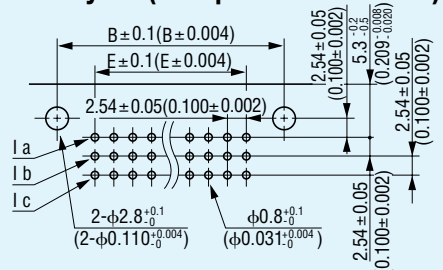

■ Dimensions

No. of contacts	A	B	C	D	E	Number of packaging
48	53.26 (2.097)	48.26 (1.900)	46.86 (1.845)	44.66 (1.758)	38.10 (1.500)	180
96	93.90 (3.697)	88.90 (3.500)	87.50 (3.445)	85.30 (3.358)	78.74 (3.100)	100

Packaging style
Other

8330-□□□-283□-□□□-N

Socket Receptacle, 3 row type

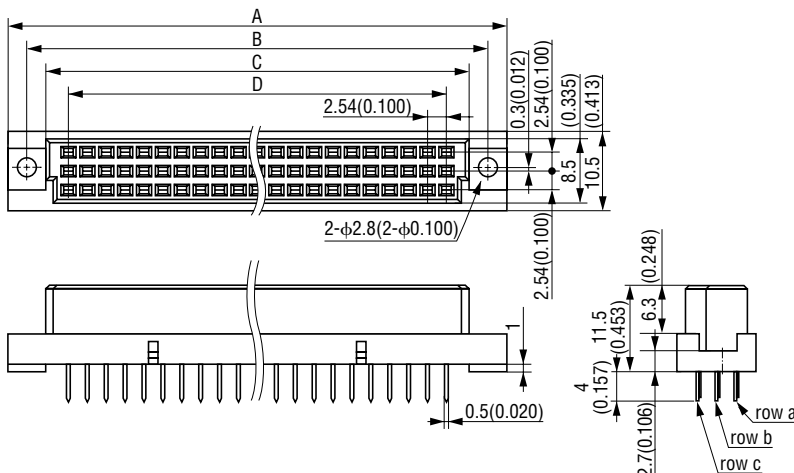

PCB Layout (Component Side View)

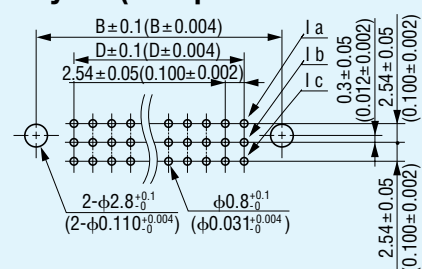

■ Dimensions

No. of contacts	A	B	C	D	Number of packaging
48	54.36 (2.140)	49.36 (1.943)	44.26 (1.743)	38.10 (1.500)	240
96	95.00 (3.740)	90.00 (3.543)	84.90 (3.343)	78.74 (3.100)	70

Packaging style
Other

8431-□□□-294□-□□□-N

Pin Receptacle, 2 row type

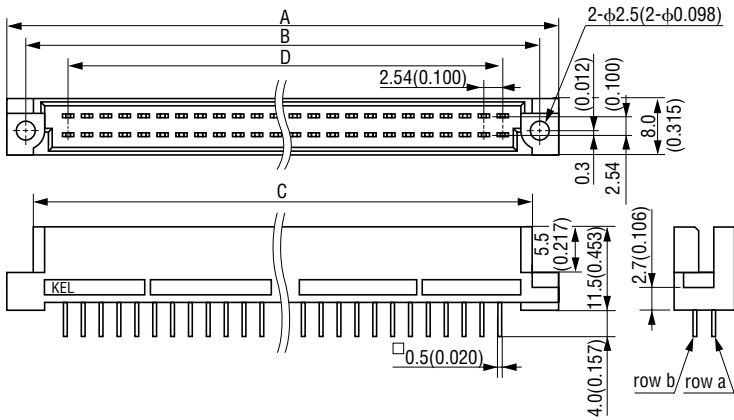
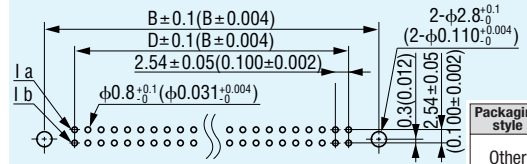
PCB Layout (Component Side View)

Product Table / Dimensions

No. of contacts	Part Number	A	B	C	D	Number of packaging
32	8431-032-294□-□□□-N	53.26 (2.097)	49.36 (1.943)	46.86 (1.845)	38.10 (1.500)	300
44	8431-044-294□-□□□-N	68.50 (2.697)	64.60 (2.543)	62.10 (2.445)	53.34 (2.100)	260
50	8431-050-294□-□□□-N	76.12 (2.839)	72.22 (2.843)	69.72 (2.745)	60.96 (2.400)	240
64	8431-064-294□-□□□-N	93.90 (3.697)	90.00 (3.543)	87.50 (3.445)	78.74 (3.100)	180
90	8431-090-294□-□□□-N	126.92 (4.997)	123.02 (4.843)	120.52 (4.745)	111.76 (4.400)	120
100	8431-100-294□-□□□-N	139.62 (5.497)	135.72 (5.343)	133.22 (5.245)	124.46 (4.900)	120

8440-□□□-284□-□□□-N

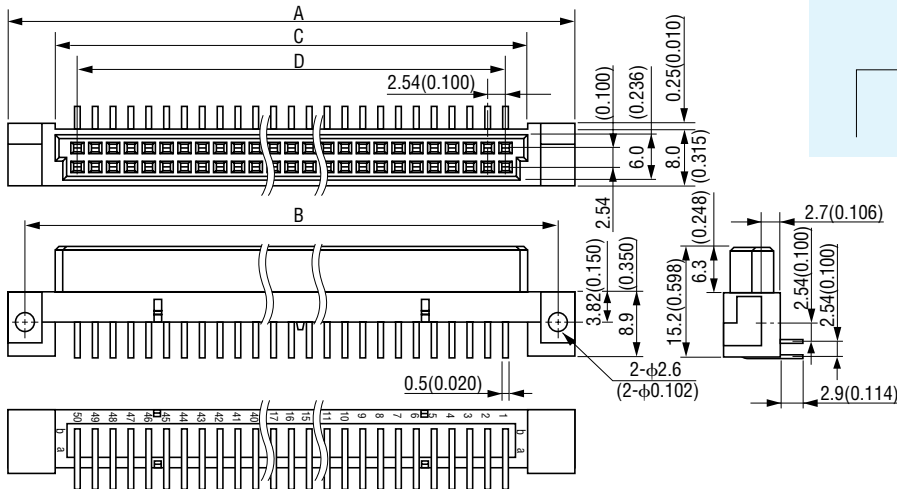
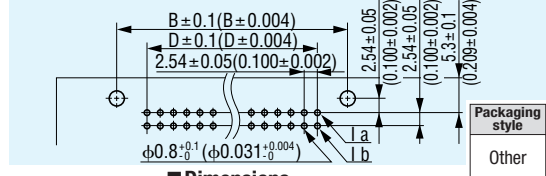
R/A Socket Header (Flush Mounting), 2 row type

PCB Layout (Component Side View)

Dimensions

No. of contacts	A	B	C	D	Number of packaging
32	58.34 (2.297)	53.34 (2.100)	44.26 (1.743)	38.10 (1.500)	300
44	73.58 (2.897)	68.58 (2.700)	59.50 (2.343)	53.34 (2.100)	225
50	81.20 (3.197)	76.20 (3.000)	67.12 (2.643)	60.96 (2.400)	225
64	98.98 (3.897)	93.98 (3.700)	84.90 (3.343)	78.74 (3.100)	170
90	132.00 (5.197)	127.00 (5.000)	117.92 (4.643)	111.76 (4.400)	110
100	144.70 (5.697)	139.70 (5.500)	130.62 (5.143)	124.46 (4.900)	115

8431-□□□-294□-□□□□-N

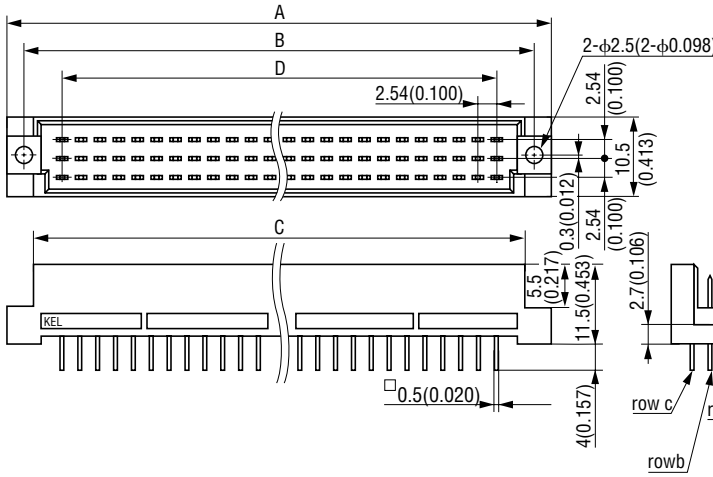
Pin Receptacle, 3 row type



PCB Layout (Component Side View)

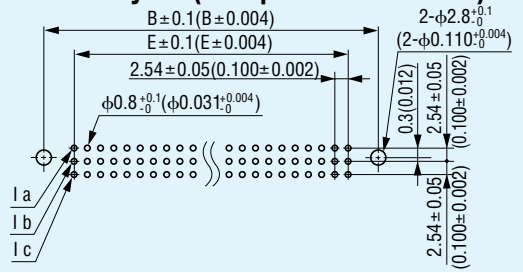

Product Table / Dimensions

No. of contacts	Part Number	A	B	C	E	Number of packaging
48	8431-048-294□□□□-N	53.36 (2.101)	49.36 (1.943)	46.86 (1.845)	38.10 (1.500)	240
96	8431-096-294□□□□-N	94.00 (3.701)	90.00 (3.543)	87.50 (3.045)	78.74 (3.100)	140

Other

8440-□□□-284□-□□□□-N

R/A Pin Header (Flush Mounting), 3 row type

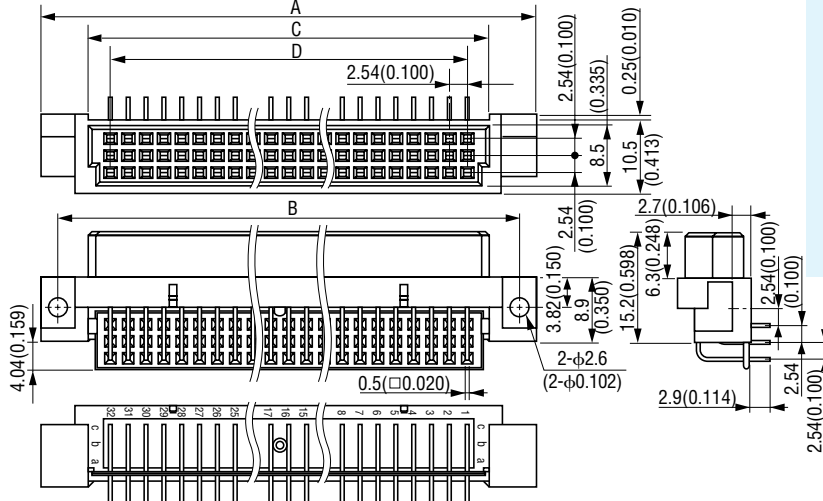

PCB Layout (Component Side View)

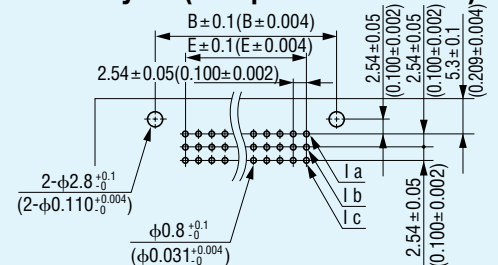

Dimensions

No. of contacts	A	B	C	E	Number of packaging
48	58.34 (2.297)	53.34 (2.100)	44.26 (1.743)	38.10 (1.500)	165
96	98.98 (3.897)	93.98 (3.700)	84.90 (3.343)	78.74 (3.100)	95

Other

ORDER CODE

8□□□-□□□-2□□□-□□□□-N

- N : RoHS Compliance
- Option
- H : With hooks (8330,8331,8341 series only)
- Insulator color
- Omit : Black
- Plating of contact area
- Omit : Au0.01μm
- Contact Terminal Style
- 283 : Straight · Dip Solder (8330 Series Socket Receptacle)
- 284 : R/A · Dip Solder (8440 Series Socket Header)
- 294 : R/A · Dip Solder (8331,8341 Series Pin Header)
- 294 : Straight · Dip Solder (8431 Pin Receptacle)
- Number of contacts
- 032,044,050,064,090,100 : 2 row type
- 048,096 : 3 row type
- Series
- 8330 : Standard Din (Socket Receptacle)
- 8331 : Standard Din (Pin Header)
- 8341 : Standard Din (Pin Header for Flush Mounting)
- 8431 : Inverse Din (Pin Receptacle for Flush Mounting)
- 8440 : Inverse Din (Socket Header)

8301-□□□-290□□-N

R/A Pin Header, 2 row type

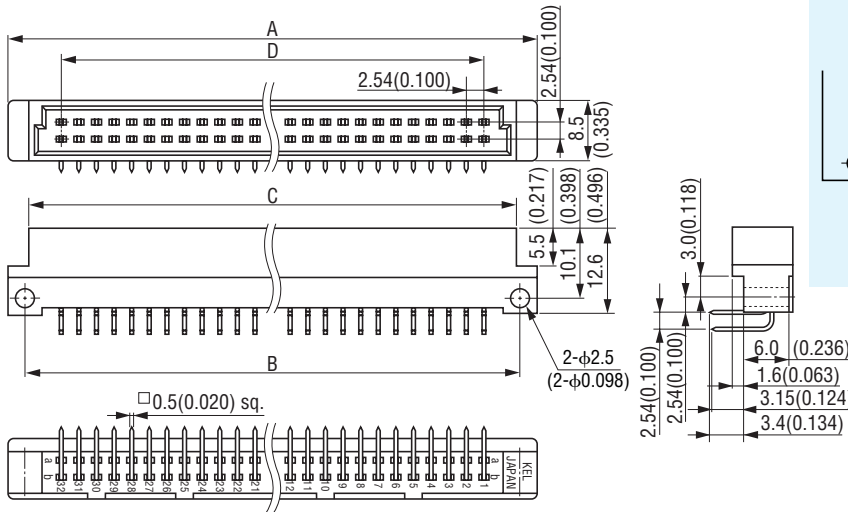
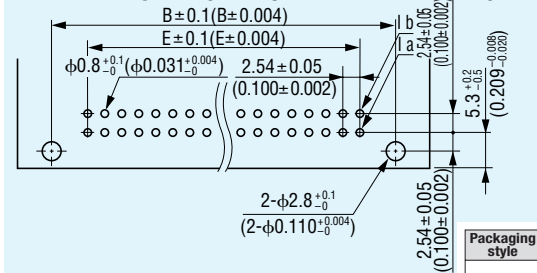
PCB Layout (Component Side View)

■ Dimensions

No. of contacts	A	B	C	E	Number of packaging
32	53.26 (2.097)	48.26 (1.900)	46.86 (1.845)	38.10 (1.500)	280
50	76.12 (2.997)	71.12 (2.800)	69.72 (2.745)	60.96 (2.400)	210
64	93.90 (3.697)	88.90 (3.500)	87.50 (3.445)	78.74 (3.100)	165

8311-□□□-290□□-N

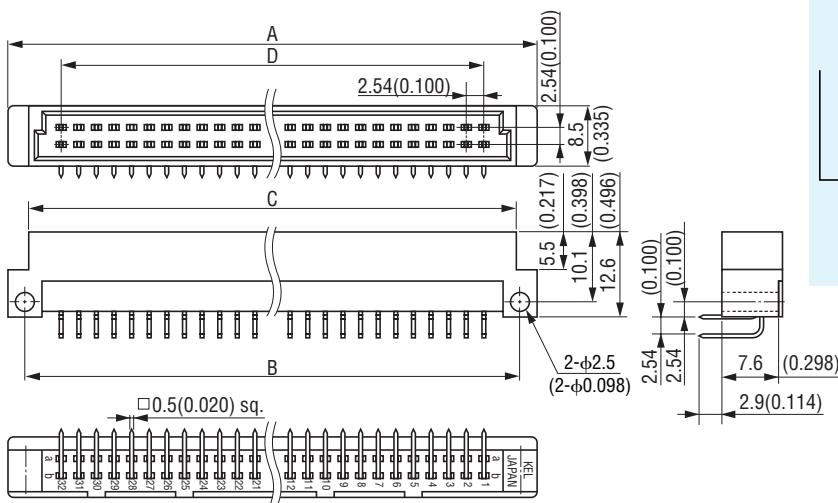
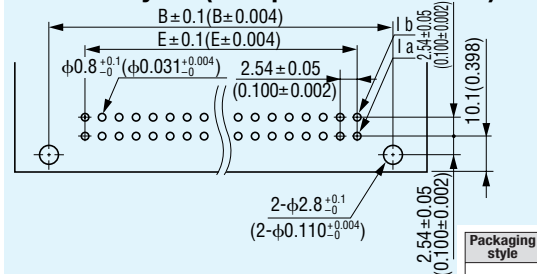
R/A Pin Header (Flush Mounting), 2 row type

PCB Layout (Component Side View)

■ Dimensions

No. of contacts	A	B	C	E	Number of packaging
32	53.26 (2.097)	48.26 (1.900)	46.86 (1.845)	38.10 (1.500)	280
50	76.12 (2.997)	71.12 (2.800)	69.72 (2.745)	60.96 (2.400)	210
64	93.90 (3.697)	88.90 (3.500)	87.50 (3.445)	78.74 (3.100)	165

8300-□□□-280□□-N
281□□-N

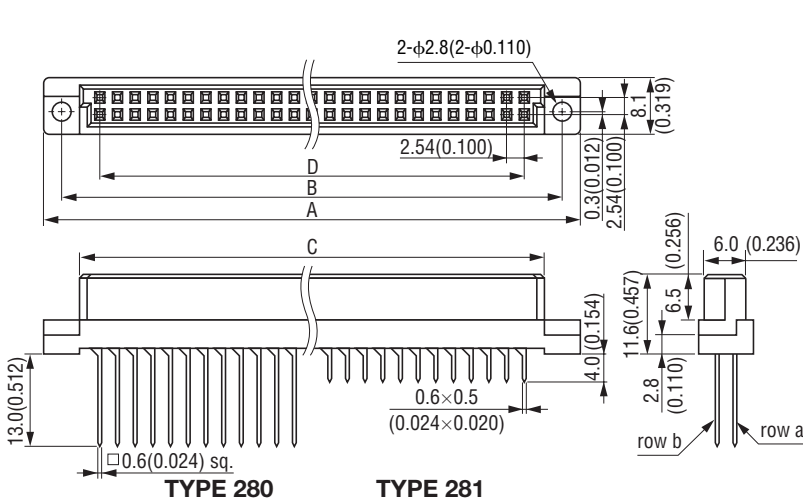
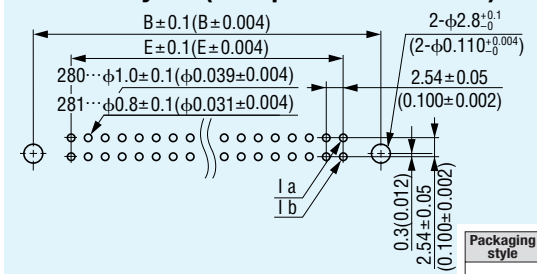
Socket Receptacle, 2 row type

PCB Layout (Component Side View)

■ Product Table / Dimensions

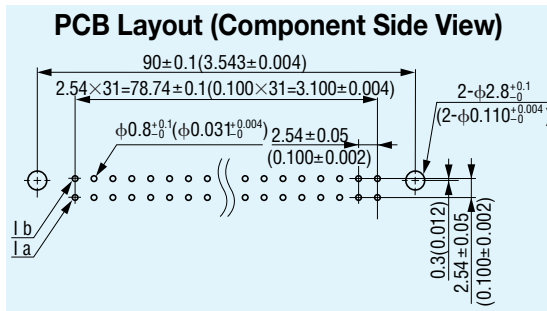
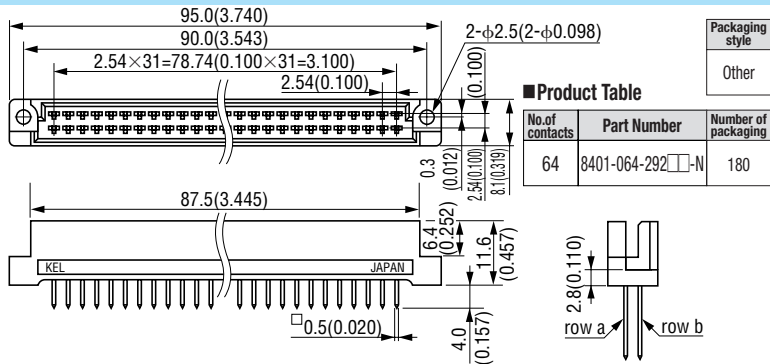
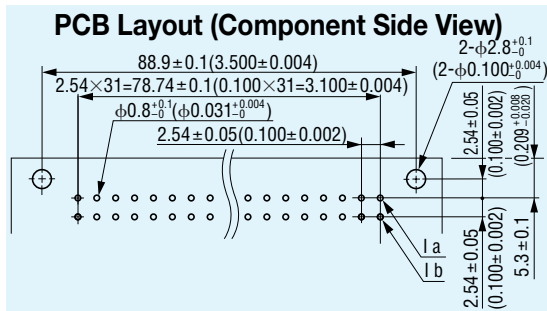
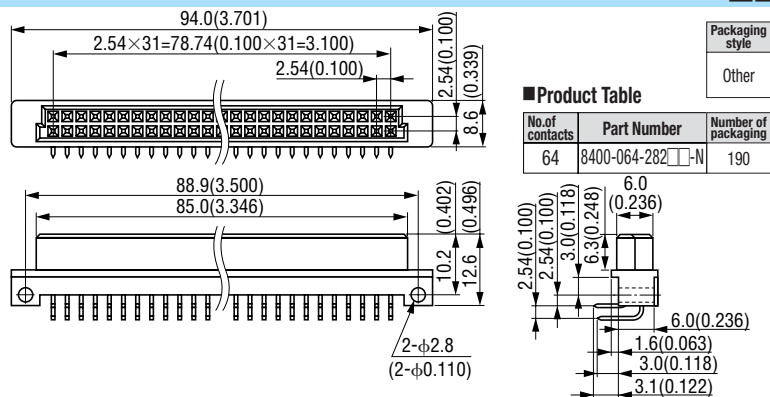
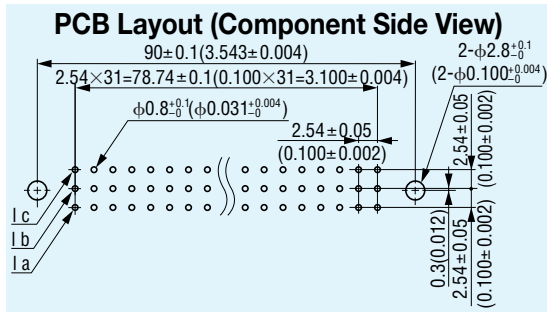
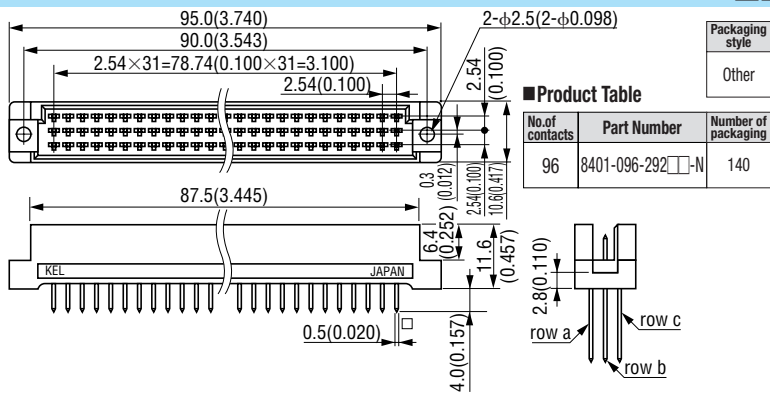
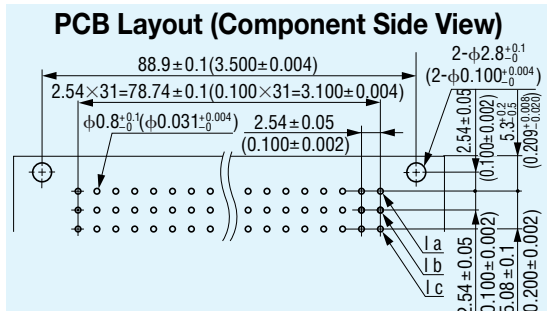
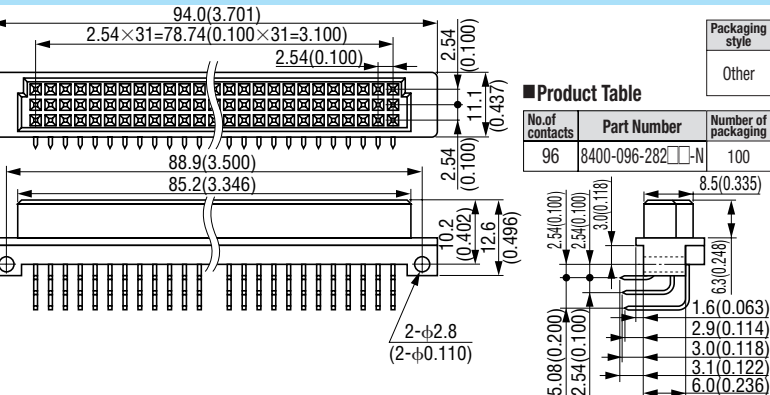
No. of contacts	Part Number	A	B	C	E	Number of packaging
32	8300-032-280□□-N	54.36 (2.140)	49.36 (1.943)	44.36 (1.746)	38.10 (1.500)	160
	8300-032-281□□-N					320
50	8300-050-280□□-N	77.22 (3.040)	72.22 (2.843)	67.22 (2.646)	60.96 (2.400)	110
	8300-050-281□□-N					230
64	8300-064-280□□-N	95.00 (3.740)	90.00 (3.543)	85.00 (3.346)	78.74 (3.100)	90
	8300-064-281□□-N					180

8401-064-292 □□-N

8400-064-282 □□-N

8401-096-292 □□-N

8400-096-282 □□-N

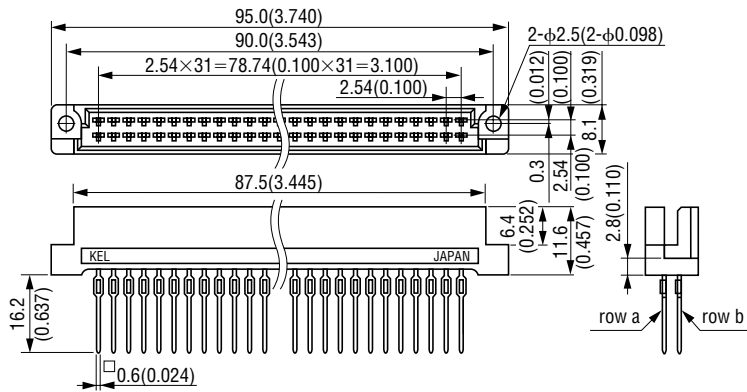
8401-064-293□□-N

Pin Receptacle (Press-fit), 2 row type

Unit:mm(inch)



■ Product Table

No. of contacts	Part Number	Number of packaging
64	8401-064-293□□-N	90

Packaging style	Other
-----------------	-------

PCB Layout (Component Side View)

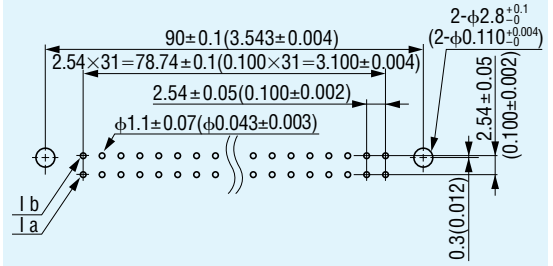

8401-096-293□□-N

Pin Receptacle (Press-fit), 3 row type

Unit:mm(inch)

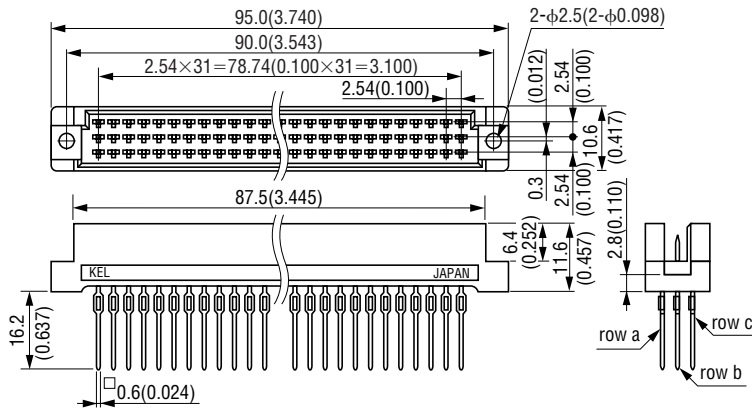

■ Product Table

No. of contacts	Part Number	Number of packaging
96	8401-096-293□□-N	70

Packaging style	Other
-----------------	-------

PCB Layout (Component Side View)

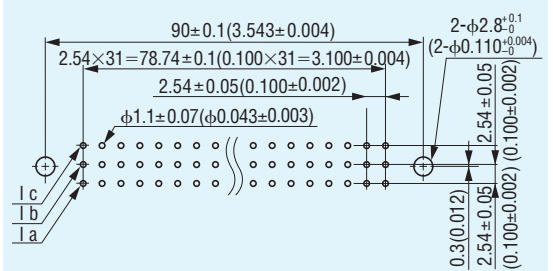

● ORDER CODE

8 □ □ - **0** □ □ - **2** □ □ □ □ - **N**

- Series
 - 8300 : Standard Din (Socket Receptacle)
 - 8301 : Standard Din (Pin Header)
 - 8311 : Standard Din (Pin Header for Flush Mounting)
 - 8400 : Inverse Din (Socket Header)
 - 8401 : Inverse Din (Pin Receptacle for)
- Number of contacts
 - 032,050,064 : 2 row type
 - 048,096 : 3 row type
- Terminal Style
 - 280 : Straight · Wire Wrap (8300 Series Socket Receptacle)
 - 281 : Straight · Dip Solder (8300 Series Socket Receptacle)
 - 282 : Right Angle · Dip Solder (8400 Series Socket Header)
 - 290 : Right Angle · Dip Solder (8301, 8311 Series Pin Header)
 - 292 : Straight · Dip Solder (8401 Series Pin Receptacle)
 - 293 : Press-fit Wire Wrap (8401 Series Pin Receptacle)
- Plating thickness
 - Omit : Au 0.2μm (Standard)
- Contact arrangement
 - Omit : row a,b,c
- N : RoHS Compliance

Vertical mating		Vertical mating																																					
2 rows	3 rows	2 rows	3 rows																																				
<p> a 8331-□□-294-□-N b 8301-□□-290-□-N c 8330-□□-283-□-N d 8300-□□-280-□-N / 281-□-N </p> <p>3.55(0.140) 2.54(0.100) 0.3(0.012)</p>	<p> a 8331-□□-294-□-N b 8301-□□-290-□-N c 8330-□□-283-□-N d 8300-□□-280-□-N / 281-□-N </p> <p>3.55(0.140) 2.54(0.100) 0.3(0.012)</p>	<p> a 8341-□□-294-□-N b 8311-□□-290-□-N c 8330-□□-283-□-N d 8300-□□-280-□-N / 281-□-N </p> <p>Table 2 2.54(0.100) 0.3</p>	<p> a 8341-□□-294-□-N b 8311-□□-290-□-N c 8330-□□-283-□-N d 8300-□□-280-□-N / 281-□-N </p> <p>Table 2 2.54(0.100) 0.3</p>																																				
<table border="1" style="font-size: small;"> <thead> <tr><th>Table 1</th><th>c</th><th>d</th></tr> </thead> <tbody> <tr><td>a</td><td>17.84 (0.702)</td><td>17.74 (0.698)</td></tr> <tr><td>b</td><td>17.84 (0.702)</td><td>17.74 (0.698)</td></tr> </tbody> </table>	Table 1	c	d	a	17.84 (0.702)	17.74 (0.698)	b	17.84 (0.702)	17.74 (0.698)	<table border="1" style="font-size: small;"> <thead> <tr><th>Table 1</th><th>c</th><th>d</th></tr> </thead> <tbody> <tr><td>a</td><td>17.84 (0.702)</td><td>17.74 (0.698)</td></tr> <tr><td>b</td><td>17.84 (0.702)</td><td>17.74 (0.698)</td></tr> </tbody> </table>	Table 1	c	d	a	17.84 (0.702)	17.74 (0.698)	b	17.84 (0.702)	17.74 (0.698)	<table border="1" style="font-size: small;"> <thead> <tr><th>Table 1</th><th>c</th><th>d</th></tr> </thead> <tbody> <tr><td>a</td><td>17.84 (0.702)</td><td>17.74 (0.698)</td></tr> <tr><td>b</td><td>17.84 (0.702)</td><td>17.74 (0.698)</td></tr> </tbody> </table>	Table 1	c	d	a	17.84 (0.702)	17.74 (0.698)	b	17.84 (0.702)	17.74 (0.698)	<table border="1" style="font-size: small;"> <thead> <tr><th>Table 1</th><th>c</th><th>d</th></tr> </thead> <tbody> <tr><td>a</td><td>17.84 (0.702)</td><td>17.74 (0.698)</td></tr> <tr><td>b</td><td>17.84 (0.702)</td><td>17.74 (0.698)</td></tr> </tbody> </table>	Table 1	c	d	a	17.84 (0.702)	17.74 (0.698)	b	17.84 (0.702)	17.74 (0.698)
Table 1	c	d																																					
a	17.84 (0.702)	17.74 (0.698)																																					
b	17.84 (0.702)	17.74 (0.698)																																					
Table 1	c	d																																					
a	17.84 (0.702)	17.74 (0.698)																																					
b	17.84 (0.702)	17.74 (0.698)																																					
Table 1	c	d																																					
a	17.84 (0.702)	17.74 (0.698)																																					
b	17.84 (0.702)	17.74 (0.698)																																					
Table 1	c	d																																					
a	17.84 (0.702)	17.74 (0.698)																																					
b	17.84 (0.702)	17.74 (0.698)																																					

Vertical mating		Vertical mating																									
2 rows	3 rows	2 rows	3 rows																								
<p> a 8400-064-282-□-N b 8431-064-294-□-N c 8401-064-292-□-N </p> <p>3.55(0.140) 2.54(0.100) 0.3(0.012)</p>	<p> a 8400-096-282-□-N b 8431-096-294-□-N c 8401-096-292-□-N </p> <p>3.55(0.140) 2.54(0.100) 0.3(0.012)</p>	<p> a 8440-□□-284-□-N b 8431-□□-294-□-N c 8401-064-292-□-N </p> <p>5.22(0.203) 2.54(0.100) 0.3(0.012)</p>	<p> a 8440-□□-284-□-N b 8431-□□-294-□-N c 8401-096-292-□-N </p> <p>5.22(0.203) 2.54(0.100) 0.3(0.012)</p>																								
<table border="1" style="font-size: small;"> <thead> <tr><th>Table 1</th><th>b</th><th>c</th></tr> </thead> <tbody> <tr><td>a</td><td>17.94 (0.706)</td><td>18.04 (0.710)</td></tr> </tbody> </table>	Table 1	b	c	a	17.94 (0.706)	18.04 (0.710)	<table border="1" style="font-size: small;"> <thead> <tr><th>Table 1</th><th>b</th><th>c</th></tr> </thead> <tbody> <tr><td>a</td><td>17.94 (0.706)</td><td>18.04 (0.710)</td></tr> </tbody> </table>	Table 1	b	c	a	17.94 (0.706)	18.04 (0.710)	<table border="1" style="font-size: small;"> <thead> <tr><th>Table 1</th><th>b</th><th>c</th></tr> </thead> <tbody> <tr><td>a</td><td>17.81 (0.701)</td><td>17.91 (0.705)</td></tr> </tbody> </table>	Table 1	b	c	a	17.81 (0.701)	17.91 (0.705)	<table border="1" style="font-size: small;"> <thead> <tr><th>Table 1</th><th>b</th><th>c</th></tr> </thead> <tbody> <tr><td>a</td><td>17.81 (0.701)</td><td>17.91 (0.705)</td></tr> </tbody> </table>	Table 1	b	c	a	17.81 (0.701)	17.91 (0.705)
Table 1	b	c																									
a	17.94 (0.706)	18.04 (0.710)																									
Table 1	b	c																									
a	17.94 (0.706)	18.04 (0.710)																									
Table 1	b	c																									
a	17.81 (0.701)	17.91 (0.705)																									
Table 1	b	c																									
a	17.81 (0.701)	17.91 (0.705)																									

Horizontal mating		Stacked mating										
2 rows	3 rows	2 rows										
<p> 8400-064-282-□-N 8331-064-294-□-N 8301-064-290-□-N </p> <p>(0.100) 2.54 2.54 (0.100) 19.08</p>	<p> 8400-096-282-□-N 8331-096-294-□-N 8301-096-290-□-N </p> <p>(0.100) 2.54 2.54 (0.100) 19.08</p>	<p> a 8330-□□-283-□-N b 8300-□□-280-□-N / 281-□-N c 8431-□□-294-□-N d 8401-□□-292-□-N </p> <p>0.3(0.012) Table 1 0.3(0.012)</p>										
		<table border="1" style="font-size: small;"> <thead> <tr><th>Table 1</th><th>c</th><th>d</th></tr> </thead> <tbody> <tr><td>a</td><td>16.7 (0.657)</td><td>16.8 (0.661)</td></tr> <tr><td>b</td><td>16.6 (0.654)</td><td>16.7 (0.657)</td></tr> </tbody> </table>		Table 1	c	d	a	16.7 (0.657)	16.8 (0.661)	b	16.6 (0.654)	16.7 (0.657)
Table 1	c	d										
a	16.7 (0.657)	16.8 (0.661)										
b	16.6 (0.654)	16.7 (0.657)										

Horizontal mating		Stacked mating										
2 rows	3 rows	3 rows										
<p> 8440-□□-284-□-N 8341-□□-294-□-N 8311-□□-290-□-N </p> <p>(0.100) 2.54 2.54 (0.100) 19.0 (0.748)</p>	<p> 8440-□□-284-□-N 8341-□□-294-□-N 8311-□□-290-□-N </p> <p>(0.100) 2.54 2.54 (0.100) 19.0 (0.748)</p>	<p> a 8330-□□-283-□-N b 8300-□□-280-□-N / 281-□-N c 8431-□□-294-□-N d 8401-□□-292-□-N </p> <p>0.3(0.012) Table 1 0.3(0.012)</p>										
		<table border="1" style="font-size: small;"> <thead> <tr><th>Table 1</th><th>c</th><th>d</th></tr> </thead> <tbody> <tr><td>a</td><td>16.7 (0.657)</td><td>16.8 (0.661)</td></tr> <tr><td>b</td><td>16.6 (0.654)</td><td>16.7 (0.657)</td></tr> </tbody> </table>		Table 1	c	d	a	16.7 (0.657)	16.8 (0.661)	b	16.6 (0.654)	16.7 (0.657)
Table 1	c	d										
a	16.7 (0.657)	16.8 (0.661)										
b	16.6 (0.654)	16.7 (0.657)										

Horizontal mating

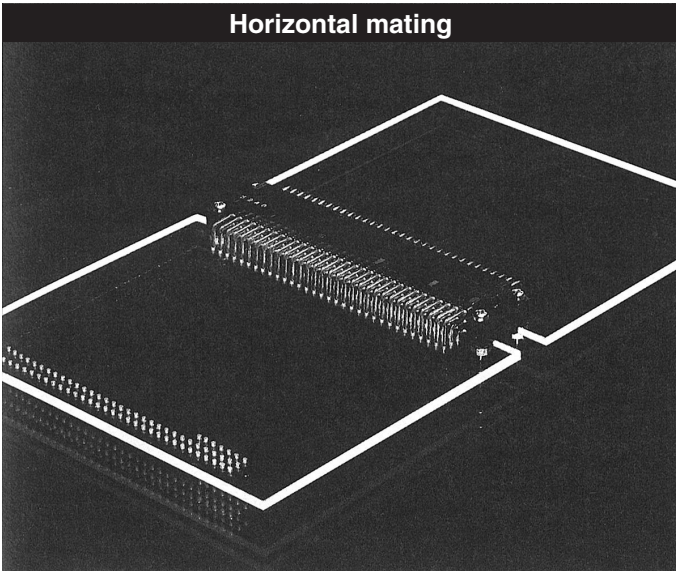

Vertical mating

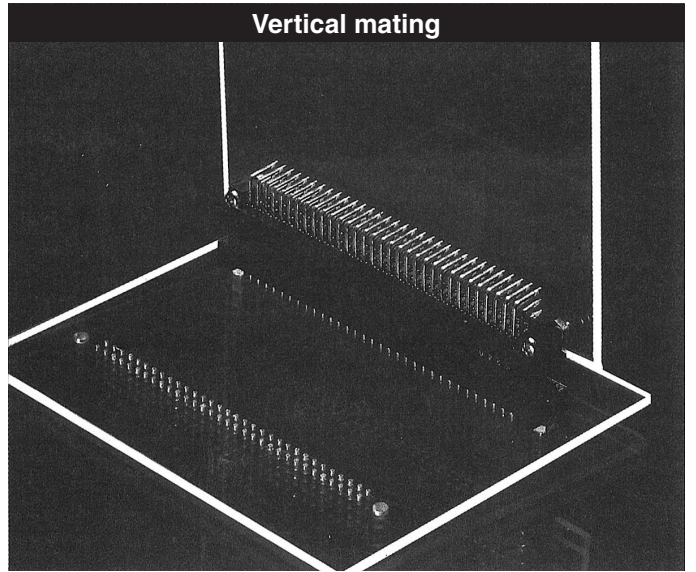

Stacked mating

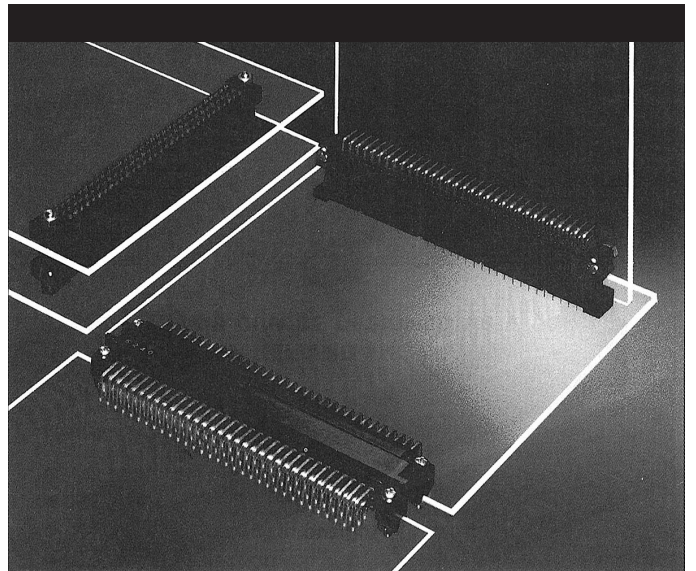
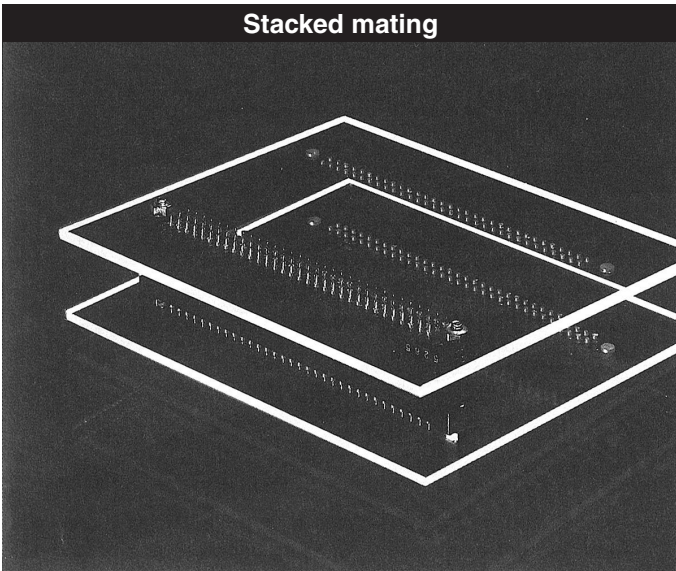

■ Compliant Part of Press-fit Contacts

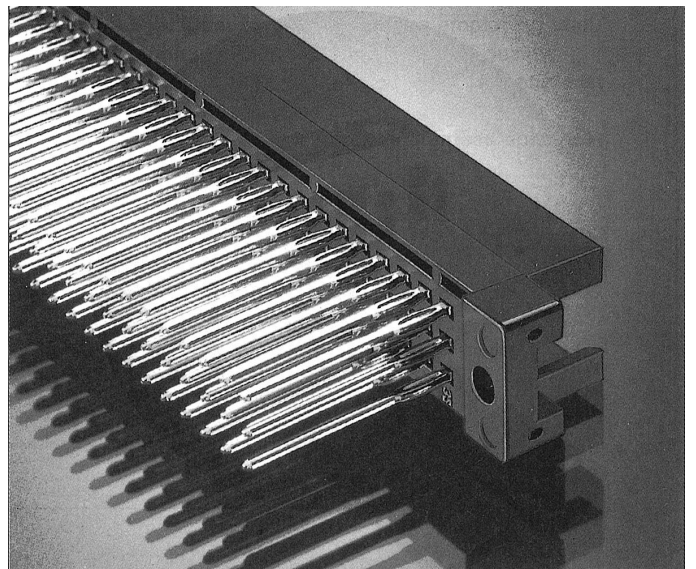

MICROSYSTEM BUS PACKAGING



KEL supplies DIN connectors to be integrated with multi-layer backpanels, power supplies into the KELRACK[®] system.

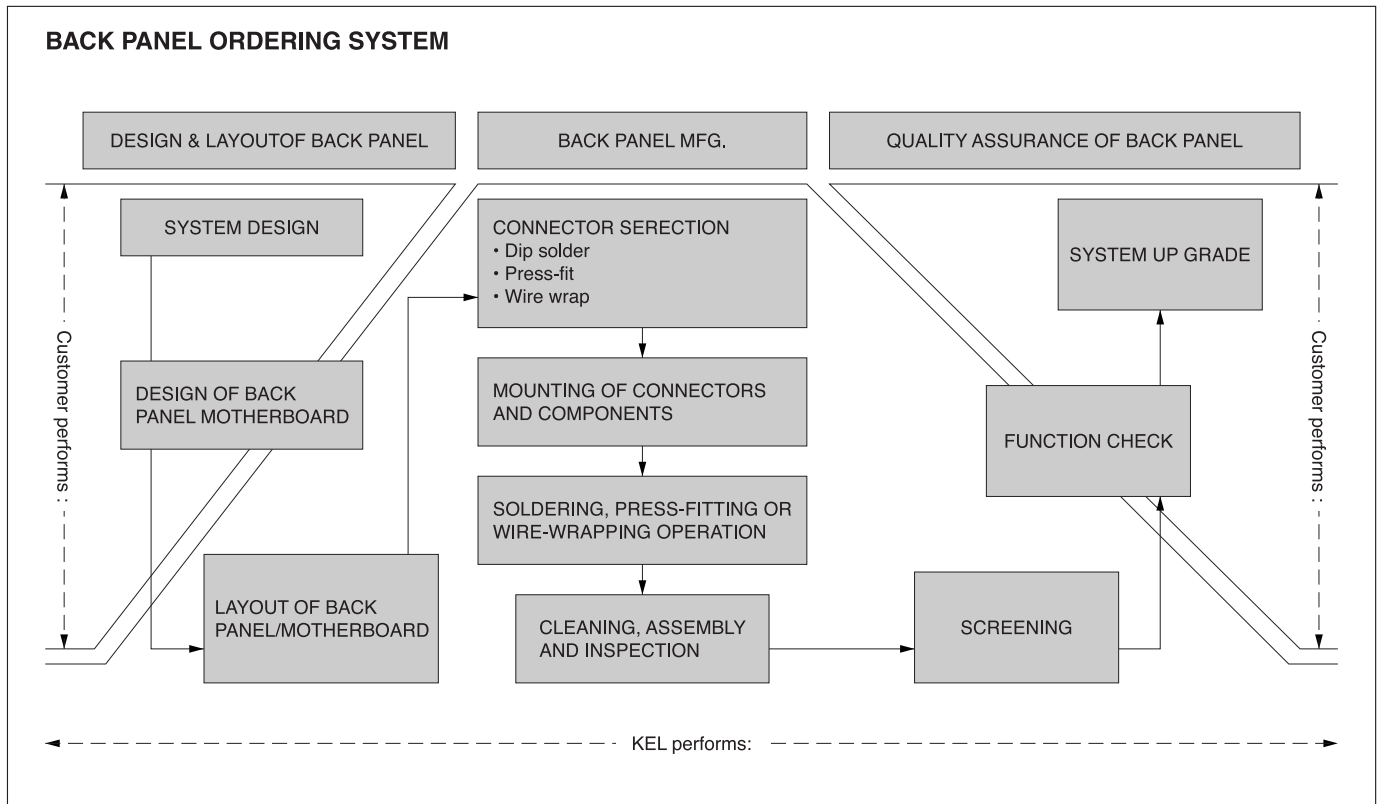

FEATURES OF MICROSYSTEM BUS PACKAGING (MBP)

- Back panels can be purchased as components
- Net cost savings by reducing design assembly and inspection cost
- Complete system of components from one source
- The appearance gives added value to the delivered product
- System design will meet industry standards
- Units can be designed and manufactured based on drawings submitted by the customer

RACK SYSTEMS CAN BE DESIGNED AS A JOINT EFFORT BETWEEN KEL AND THE CUSTOMER

TECHNICAL SUPPORT

- Microsystem bus selection
- Motherboard layout
- Rack design (strength design)
- Connector selection

ACCUMULATED KNOW-HOW AND EXPERIENCE

- Established parts inspection system.
- High-level manufacturing expertise employing standardization achieves high reliability and quality.
- Electrical circuitry is inspected by automatic test equipment and in-circuit check.
- Pre-shipment testing system guarantees specifications.